

J. N. TANNAHILL.

LATHE-GEAR.

No. 188,033.

Patented March 6, 1877.

Fig. 1

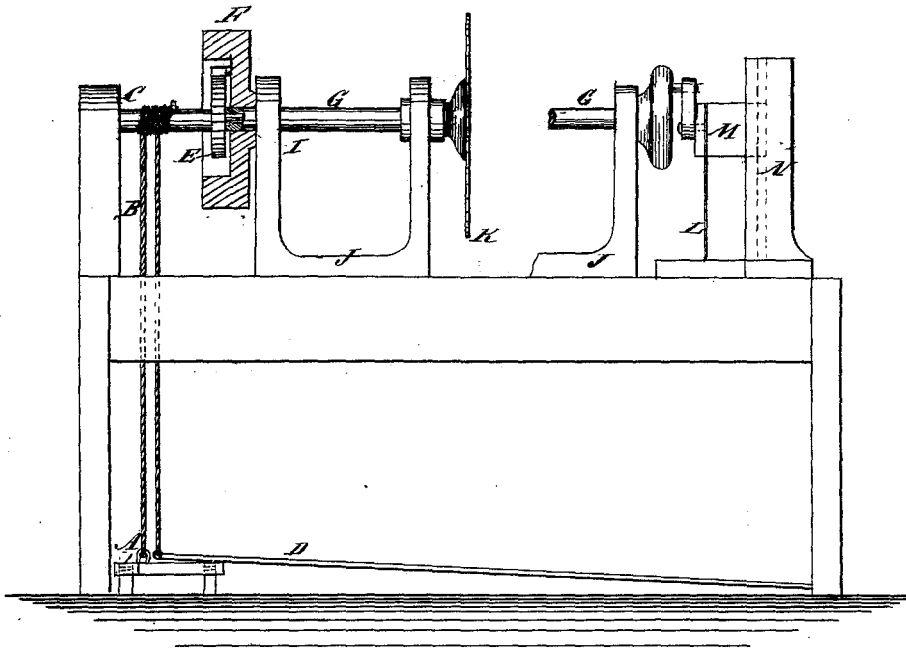
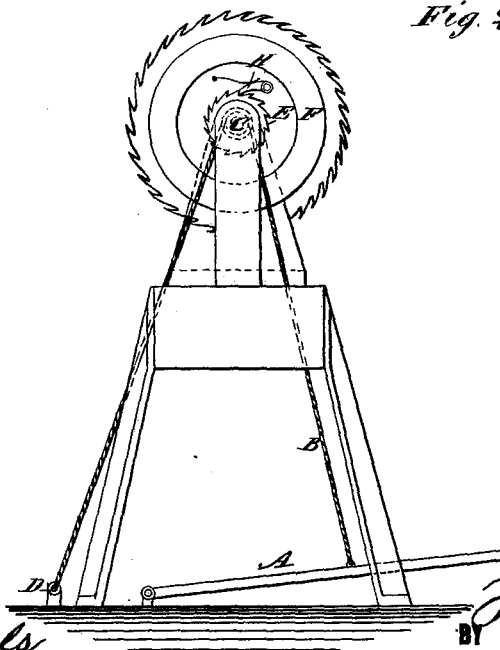

Fig. 2



WITNESSES:

C. N. ...
John Goethals.

INVENTOR:

J. N. Tannahill
BY

F. W. Lehmann.

ATTORNEY

UNITED STATES PATENT OFFICE.

JOHN N. TANNAHILL, OF BRADFORD, IOWA, ASSIGNOR TO HIMSELF AND
ELISHA A. BIGELOW, OF FARMINGTON, MINNESOTA.

IMPROVEMENT IN LATHE-GEAR.

Specification forming part of Letters Patent No. **188,033**, dated March 6, 1877; application filed
February 14, 1876.

To all whom it may concern :

Be it known that I, JOHN N. TANNAHILL, of Bradford, in the county of Chickasaw, and State of Iowa, have invented an Improvement in Lathe-Gear, of which the following is a specification :

My invention consists of a ratchet-wheel having a to-and-fro motion imparted to it by a treadle and a spring, in combination with a disk and a pawl on the lathe-spindle, circular-saw arbor, or a shaft for working a jig-saw, all being contrived so that either device may be readily connected to or disconnected from the driving-power, thereby enabling the power to be used for a greater variety of purposes than ordinary lathe-powers can be.

Figure 1 is partly a side elevation and partly a sectional elevation of my invention. Fig. 2 is an end elevation.

Similar letters of reference indicate corresponding parts.

A is the foot-treadle, from which a cord, B, passes up around the shaft C, and then down to the spring D for turning the shaft forward and backward. E is a ratchet-wheel on the shaft, which imparts continuous rotary motion to the balance-wheel disk F, and spindle or arbor G, by the pawl H on the disk, which catches the ratchet as it is turned forward, but lets it go back freely when the spring pulls the ratchet back, the balance-wheel continuing its motion meantime by its inertia.

The lathe-spindle, saw-arbor, or other shaft to be worked by the driving-shaft C will have a socket, I, for a bearing for one end of said shaft, and be mounted in movable bearing-blocks J, to be readily put in position and taken away as wanted. By thus dividing the shaft into two parts, and providing the part G with its own journals, the shaft C has nothing to do but speed the shaft G around, which it will do infinitely faster than can be done to a continuous shaft, by means of an encircling collar, because of the collar's greater diameter. Said shafts may be made to turn a circular saw, K, a jig-saw, L, or other tool. The jig-saw will be attached to a sliding head-block, M, working in a guide-post, N, or other approved contrivance.

Having thus described my invention, I claim as new and desire to secure by Letters Patent—

The combination of the shaft G, provided with its own journals, wheel F attached thereto, shaft C, ratchet-wheel E, dog H, cord or strap B, treadle A, and spring D, substantially as set forth.

JOHN N. TANNAHILL.

Witnesses:

B. W. BILLINGS,
L. M. TUCKER.